

BR 525

BRONZE GATE VALVE

PN 25

Non-Rising stem

Conforms to BS 5154/MSS SP-80



www.ecivalve.it

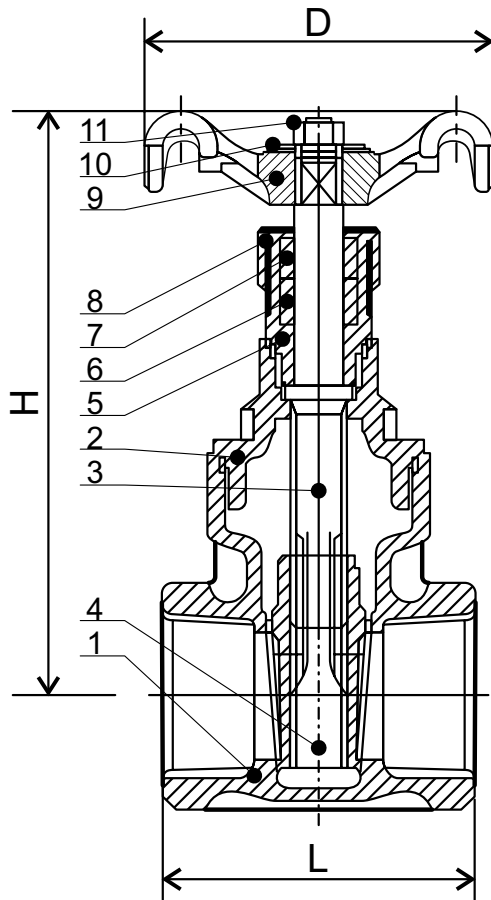

Specifications:

- PRESSURE RATING: PN25
- SUITABLE MEDIA: WATER, OIL, AIR & STEAM
- WORKING TEMPERATURE: $T \leq 170^{\circ}\text{C}$
- TAPER THREAD TO NPT AND ISO 7-1 (EX. BS-21)

Dimensions (mm)

DN	SIZE INCH	L	H	D	Weight(KGS)
8	¼"	46	75	45	0.284
10	⅜"	46	75	45	0.268
15	½"	51	82	52	0.341
20	¾"	55	95	65	0.582
25	1"	63	118	70	0.878
32	1¼"	71	144	79	1.360
40	1½"	73	166	92	1.750
50	2"	83	190	103	2.810

Materials

No.	DESCRIPTION	MATERIAL
1	Body	Bronze CC491K
2	Bonnet	Bronze CC491K
3	Stem	DZR Brass CW602N
4	Disc	Bronze CC491K
5	Stuffing Box	DZR Brass CW602N
6	Packing Ring	P.T.F.E
7	Gland	Brass CW614N
8	Packing Nut	Brass CW614N
9	Handwheel	Aluminum
10	Identification Plate	Aluminum
11	Handwheel Nut	Brass CW614N



All data, descriptions and pictures contained in this leaflet may be subject to change without prior notice.

European Casting Industry Srl | Via Lazzaretto, 11 | 20124 Milan MI, Italia | P.Iva: 03228761205 | www.ecivalve.it | info@ecivalve.it