

BR 432

BRONZE GLOBE VALVE

PN 32

Rising stem

Conforms to BS 5154/MSS SP-80



www.ecivalve.it

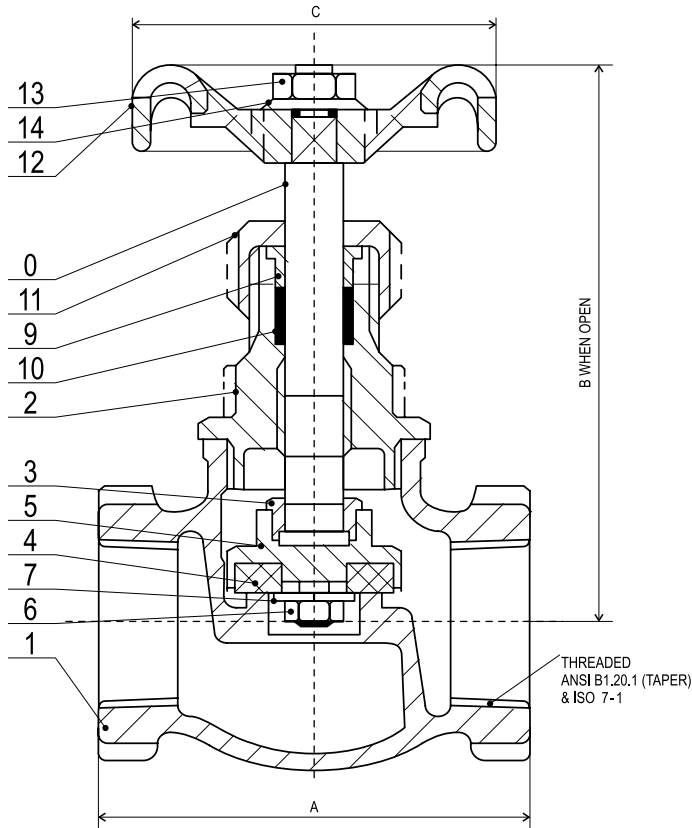

Specifications:

- PRESSURE RATING: PN32
- SUITABLE MEDIA: WATER, OIL, AIR & STEAM
- WORKING TEMPERATURE: $T \leq 180^{\circ}\text{C}$
- TAPER PIPE THREAD TO NPT AND ISO 7-1 (EX. BS-21)

Dimensions (mm)

DN	SIZE INCH	A	B	C	Weight(KGS)
15	½"	62	101	52	0.540
20	¾"	74	115	52	0.650
25	1"	90	125	70	0.810
32	1¼"	100	150	70	1.550
40	1½"	115	159	92	2.010
50	2"	136	191	103	3.080

Materials

No.	DESCRIPTION	MATERIAL
1	Body	Bronze CC491K
2	Bonnet	Bronze CC491K
3	Disc Stem Ring	Brass CW602N
4	Disc	P.T.F.E
5	Disc Holder	Bronze CC491K
6	Disc Nut	Brass CW602N
7	Washer	Brass CW602N
8	Stem	Brass CW602N
9	Gland	Brass CW614N
10	Packing	Asbestos Free
11	Packing Nut	Brass CW614N
12	Handwheel	Aluminum
13	Handwheel Nut	Brass CW614N
14	I.D Plate	Aluminum



All data, descriptions and pictures contained in this leaflet may be subject to change without prior notice.

European Casting Industry Srl | Via Lazzaretto, 11 | 20124 Milan MI, Italia | P.Iva: 03228761205 | www.ecivalve.it | info@ecivalve.it