

# BR 118

## BRONZE BALL VALVE

WORKING PRESSURE PN 25

FULL BORE

TAPER PIPE THREADED TO ISO 7

DESIGN STANDARD GB/T8464



www.ecivalve.it

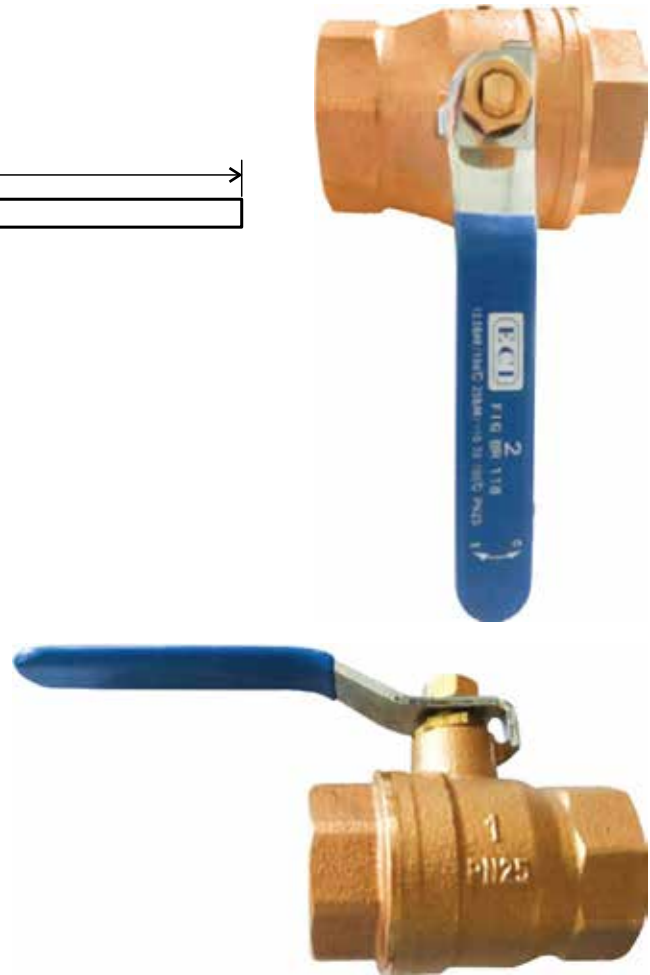
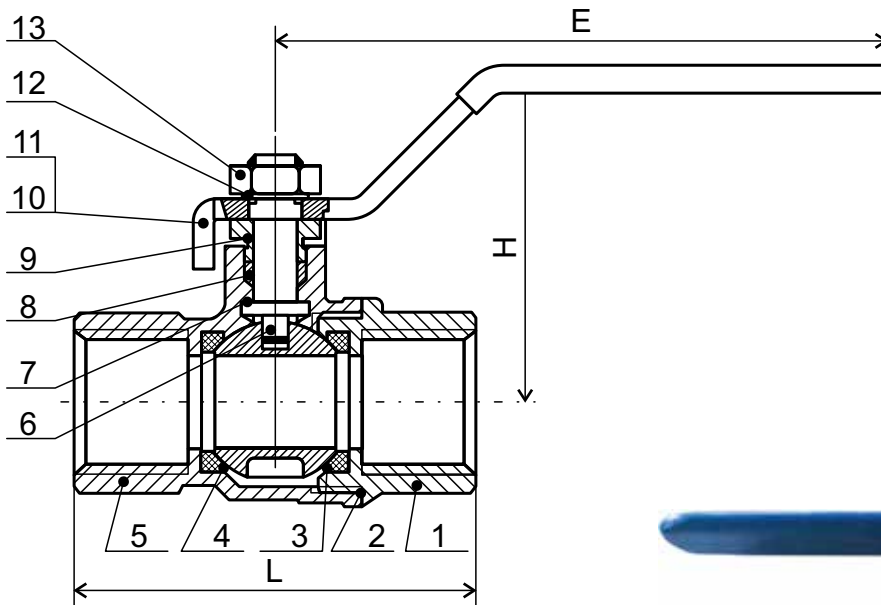

### Specifications:

- WORKING PRESSURE: PN 25
- WORKING TEMPERATURE:  $T \leq 170^{\circ}\text{C}$
- PORT SIZE:
- $\frac{1}{2}''$  UP TO  $2''$
- FULL PORT
- TESTING PRESSURE: 100 PSI AIR FOR SHELL & SEAT
- TAPER PIPE THREADED TO NPT AND ISO 7-1 (EX. BS-21)
- SUITABLE MEDIA: WATER, OIL, AIR, & STEAM

### Dimensions (mm)

DN	SIZE INCH	L	H	E	Weight(KGS)
15	$\frac{1}{2}''$	53	44	95	0.228
20	$\frac{3}{4}''$	61	51	110	0.366
25	$1''$	71	55	110	0.539
32	$1\frac{1}{4}''$	85	65	140	0.838
40	$1\frac{1}{2}''$	92	70	140	1.133
50	$2''$	114	83	160	1.880

### Materials

No.	DESCRIPTION	BRONZE
1	Seat retainer	Bronze CC491K
2	Packing	P.T.F.E
3	Seat	P.T.F.E
4	Ball	Brass CW617N
5	Body	Bronze CC491K
6	Stem	DZR Brass CW602N
7	Stem	P.T.F.E
8	Packing	P.T.F.E
9	Gland Nut	Brass CW617N
10	Lever	Mild Steel Chrome Plated
11	Lever	PVC
12	Washer	Stainless Steel
13	Nut	Stainless Steel



All data, descriptions and pictures contained in this leaflet may be subject to change without prior notice.

European Casting Industry Srl | Via Lazzaretto, 11 | 20124 Milan MI, Italia | P.Iva: 03228761205 | www.ecivalve.it | info@ecivalve.it