

BS 501

BRASS GATE VALVE

PN 16

Non-Rising stem - FXF



www.ecivalve.it

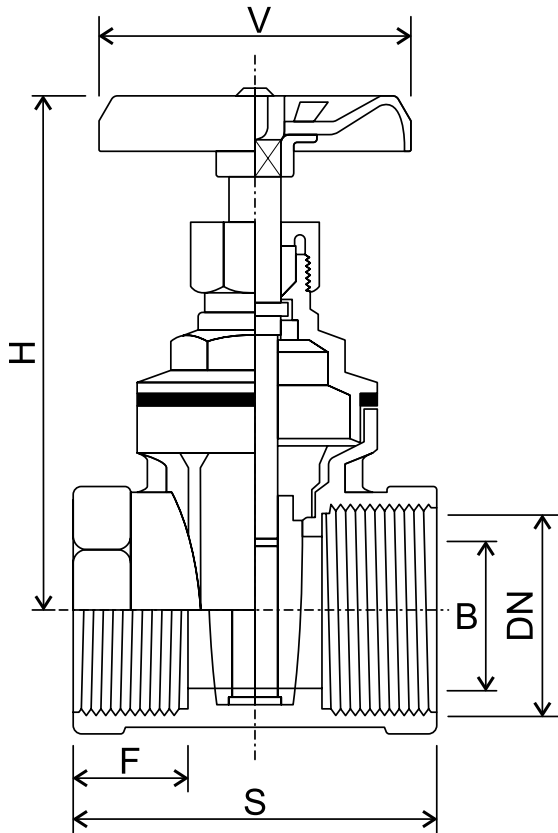

Specifications:

- PRESSURE RATING: PN16
- SUITABLE MEDIA: WATER, OIL & AIR
- WORKING TEMPERATURE: 0°C + 90°C
- ISO 288/1 THREAD FXF

Dimensions (mm)

DN	SIZE INCH	B	F	S	H	V	Weight(KGS)
15	1/2"	15	10	38	69	50	0,19
20	3/4"	19	11	44	77	50	0,26
25	1"	24	12	48	90	60	0,37
32	1.1/4"	32	13	51	97	60	0,53
40	1.1/2"	37	14	58	108	70	0,71
50	2"	47	15	63	131	80	1,16
65	2.1/2"	60	15	64	155	90	1,70
80	3"	72	18	75	183	100	2,47
100	4"	93	19	85	225	120	4,50

Materials

DESCRIPTION	MATERIAL
Body	CW617N - UNI EN 12165/98
Bonnet	CW617N - UNI EN 12165/98
Bonnet gasket	Heat resisting fiber
Stem	CW614N - UNI EN 12164/98
Wedge	CW617N - UNI EN 12165/98
Screwed ring	CW614N - UNI EN 12164/98
Packing	PTFE
Packing nut	CW614N - UNI EN 12164/98
Handwheel	Steel blue paint
Nut	Steel zinc plated



All data, descriptions and pictures contained in this leaflet may be subject to change without prior notice.

European Casting Industry Srl | Via Lazzaretto, 11 | 20124 Milan MI, Italia | P.Iva: 03228761205 | www.ecivalve.it | info@ecivalve.it