

G 203

CAST IRON STRAINER, Y TYPE

PN16 Flanged

www.ecivalve.it

ECI EUROPEAN
CASTING
INDUSTRY

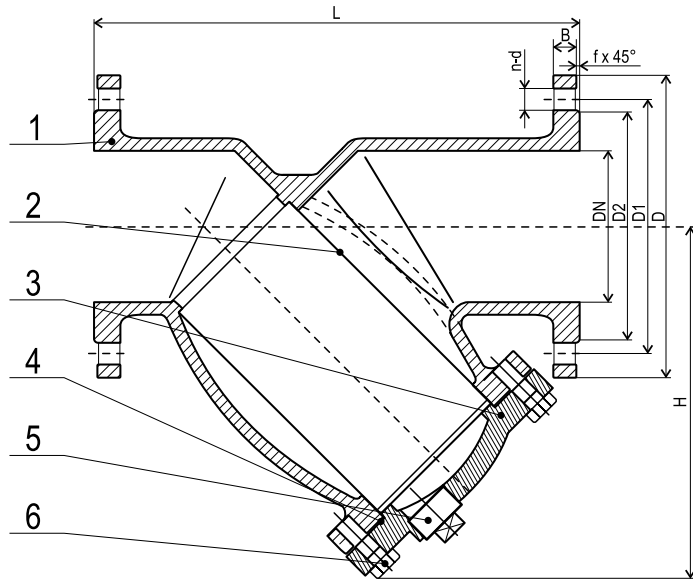

Specifications:

- 16 BAR FROM -10 TO 120 °C, 13 BAR AT 220 °C
- FLANGE DRILLED CONFORM TO BS-EN 1092-2 PN16
- FACE TO FACE DIMENSION CONFORMS TO SERIES 1 OF BS EN 558-1
- SUITABLE MEDIA: WATERS, OIL, AIR & STEAM

Materials

No.	DESCRIPTION	MATERIAL	BRITISH STANDARD
1	Body	Cast iron	1561EN JL 1030
2	Screen	Stainless	1449304S315
3	Bonnet	Cast Iron	1561EN JL 1030
4	Gasket	Graphite	Non Asbestos
5	Screw Plug	Brass	Mn Brass
6	Bolt	Steel	BS979 43A

Dimensions (mm)

DN	L	D	D1	D2	B	f	n-d	H	WEIGHT KGS
50	230	165	125	102	20	3	4-19	156	10.9
65	290	185	145	122	20	3	4-19	176	14.5
80	310	200	160	138	22	3	8-19	199	20.9
100	350	220	180	158	24	3	8-19	240	26.8
125	400	250	210	188	26	3	8-19	292	40.2
150	480	285	240	212	26	3	8-23	320	57.1
200	600	340	295	288	30	3	12-23	399	97.1
250	730	405	355	320	32	3	12-28	516	163.0
300	850	460	410	378	32	4	12-28	568	228.4
350	980	520	470	438	36	4	16-28	648	312.0
400	1100	580	525	490	38	4	16-31	759	422.0

ECI EUROPEAN
CASTING
INDUSTRY

All data, descriptions and pictures contained in this leaflet may be subject to change without prior notice.

European Casting Industry Srl | Via Lazzaretto, 11 | 20124 Milan MI, Italia | P.Iva: 03228761205 | www.ecivalve.it | info@ecivalve.it