

BS 135

BRASS CHROME PLATED BALL VALVE



www.ecivalve.it

ECI EUROPEAN
CASTING
INDUSTRY

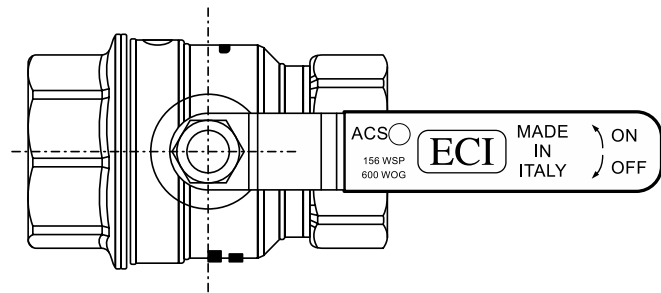
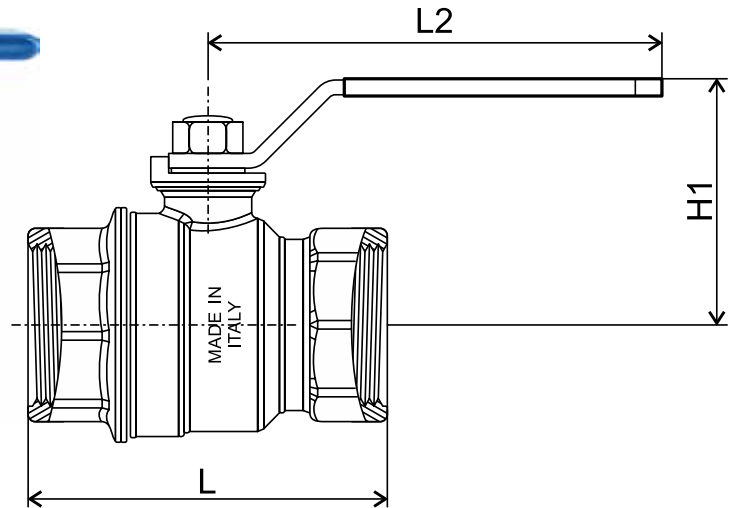

Specifications:

- FULL BORE SIZES 1/2" TO 2"
- STANDARD PASSAGE SIZES 2.1/2" UP TO 4"
- WP: 35 BAR SIZES 1/2" & 3/4" 28 BAR SIZES 1" UP TO 4"
- WORKING TEMPERATURE: $T \leq 140^{\circ}\text{C}$
- SUITABLE FOR WATER, GLYCOLATE SOLUTION (GLYCOL 50%)
- THREADED ACCORDING TO ISO 228/1
- SHELL TEST ACCORDING TO UNI EN 13828

Dimensions (mm)

| DN | SIZE INCH | L | H1 | L2 | Weight(KGS) |
|-----|-----------|-----|-----|-----|-------------|
| 15 | 1/2" | 53 | 35 | 77 | 0.177 |
| 20 | 3/4" | 60 | 47 | 95 | 0.274 |
| 25 | 1" | 74 | 51 | 95 | 0.407 |
| 32 | 1 1/4" | 84 | 56 | 95 | 0.565 |
| 40 | 1 1/2" | 95 | 69 | 137 | 0.984 |
| 50 | 2" | 109 | 77 | 137 | 1.539 |
| 65 | 2 1/2" | 146 | 102 | 173 | 2.980 |
| 80 | 3" | 160 | 109 | 173 | 4.172 |
| 100 | 4" | 207 | 200 | 187 | 7.004 |

Materials

| DESCRIPTION | MATERIAL |
|---------------|------------------------------|
| Body | Brass chrome plated EN 12540 |
| Tailpiece | Brass chrome plated EN 12540 |
| Ball | Brass chrome plated EN 12540 |
| Stem | Brass EN 12164-CW614N |
| Ball Seat | PTFE |
| Packing | PTFE |
| Handle | Galvanized steel |
| Handle Sleeve | Vinyl |
| Handle Nut | Galvanized steel |



All data, descriptions and pictures contained in this leaflet may be subject to change without prior notice.

European Casting Industry Srl | Via Lazzaretto, 11 | 20124 Milan MI, Italia | P.Iva: 03228761205 | www.ecivalve.it | info@ecivalve.it