

G 501

CAST IRON GATE VALVE

ANSI CL 125 FLANGED

Non-Rising stem

Conforms to MSS SP-70

www.ecivalve.it

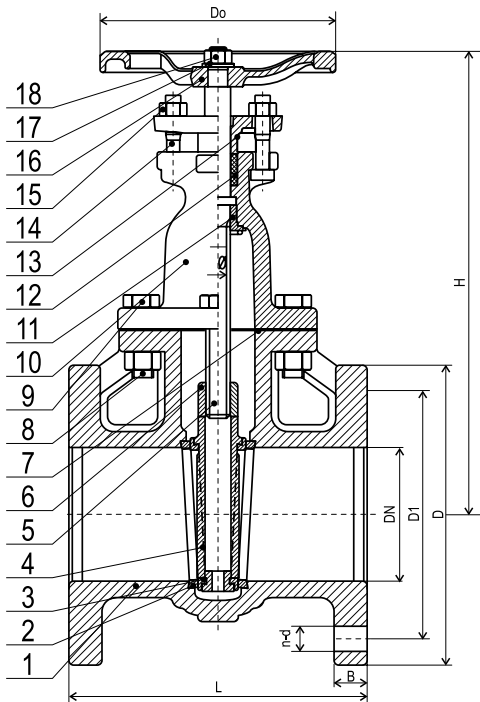

Specifications:

- INSIDE SCREW NON-RISING STEM
- 125 PSI/8.6 BAR FLUID PRESSURE TO 353°F/178°C
- 200 PSI/13.8 BAR NON-SHOCK COLD WORKING PRESSURE FROM -20°F TO 150°F/-29°C TO 66°C
- SUITABLE MEDIA: WATER & OIL
- DESIGN AND MANUFACTURE CONFORM TO MSS SP-70
- FACE TO FACE DIMENSIONS CONFORM TO ANSI B16.10
- FLANGE DRILLED CONFORM TO ANSI B16.1 CLASS 125
- GATE VALVES ARE DESIGNED TO BE IN AN OPEN OR CLOSED POSITION

Dimensions (mm)

DN	SIZE INCH	L	D	D1	n-d	B	Do	H	WEIGHT KG
50	2	178	152	121	4-19	15.9	180	240	12.0
65	2½	190	178	140	4-19	17.5	180	265	15.4
80	3	203	190	153	4-19	19.1	200	323	22.6
100	4	229	229	191	8-19	23.9	254	365	35.8
125	5	254	254	216	8-22	23.9	254	413	47.6
150	6	267	279	241	8-22	25.4	300	477	63.0
200	8	292	343	299	8-22	28.6	300	585	106
250	10	330	406	362	12-25	30.2	350	710	168
300	12	356	483	432	12-25	31.8	400	789	243
350	14"	381	533.4	476.3	12-28.6	34.9	560	987	391
400	16"	406.4	597	539.8	16-28.6	36.5	560	1044	520
450	18"	432	635	578	16-32	39.7	610	1148	684
500	20"	457	699	635	20-32	42.9	610	1257	800
600	24"	508	813	749.5	20-35	47.6	765	1418	1205

Materials

No.	DESCRIPTION	MATERIAL	AMERICAN STANDARD
1	Body	Cast Iron	ASTM A 126 B
2	Body Seat Ring	Bronze	ASTM B 62
3	Wedge Seat Ring	Bronze	ASTM B 62
4	Wedge	Cast Iron	ASTM A 126 B
5	Stem	Brass	ASTM B 16
6	Stem Nut	Brass	ASTM B584 C84400
7	Gasket	Graphite	Non Asbestos
8	Bolt	Steel	ASTM A 307
9	Nut	Steel	ASTM A 307
10	Bonnet	Cast Iron	ASTM A 126 B
11	Bonnet Bush	Brass	ASTM B584 C84400
12	Packing	Graphite	Non Asbestos
13	Gland Follower	Ductile Iron	ASTM A536 60-40-18
14	Bolt	Steel	ASTM A 307
15	Nut	Steel	ASTM A 307
16	Handwheel	Cast Iron	ASTM A 126
17	Washer	Steel	ASTM A 307
18	Handwheel Nut	Steel	ASTM A 307



All data, descriptions and pictures contained in this leaflet may be subject to change without prior notice.

European Casting Industry Srl | Via Lazzaretto, 11 | 20124 Milan MI, Italia | P.Iva: 03228761205 | www.ecivalve.it | info@ecivalve.it