

G 401

CAST IRON GLOBE VALVE
ANSI CL 125 FLANGED
OUTSIDE SCREW & YOKE
CONFORMS TO MSS SP-85

www.ecivalve.it

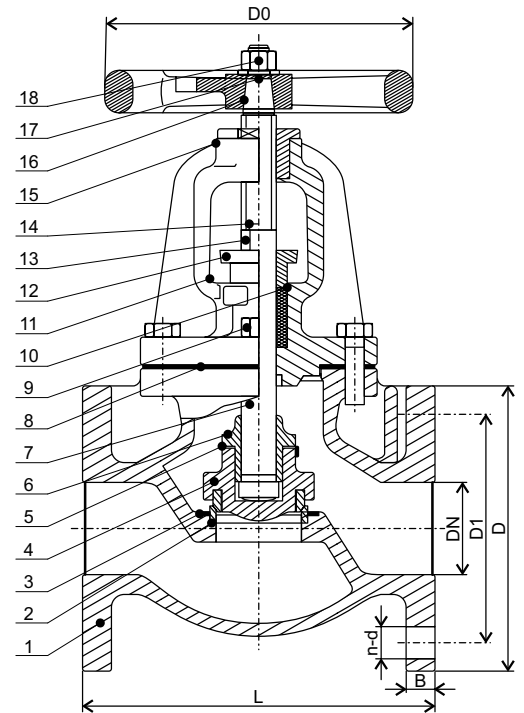

Specifications:

- OUTSIDE SCREW & YOKE
- 125 PSI/8.6 BAR FLUID PRESSURE TO 384°F/230°C
- 200 PSI/13.8 BAR NON-SHOCK COLD WORKING PRESSURE FROM -20°F TO 150°F/ -29°C TO 66°C
- SUITABLE MEDIA: WATER, OIL, AIR & STEAM
- DESIGN AND MANUFACTURE CONFORM TO MSS SP-85
- FACE TO FACE DIMENSIONS CONFORM TO ANSI B16.10
- FLANGE DRILLED CONFORM TO ANSI B16.1 CLASS 125

Dimensions (mm)

DN	NCH	L	D	D1	n-d	B	Do	WEIGHT KGS
50	2	203	152	121	4-19	15.9	180	15.6
65	2½	216	178	140	4-19	17.5	180	21.5
80	3	241	190	153	4-19	19.1	200	30.9
100	4	292	229	191	8-19	23.9	254	46.8
125	5	330	254	216	8-22	23.9	254	68.4
150	6	356	279	241	8-22	25.4	300	92.6
200	8	495	343	299	8-22	28.6	300	157
250	10	622	406	362	12-25	30.2	350	229
300	12	698	483	432	12-25	31.8	400	318

Materials

No.	DESCRIPTION	MATERIAL	AMERICAN STANDARD
1	Body	Cast Iron	ASTM A 126 B
2	Body Seat Ring	Bronze	ASTM B 62
3	Disc Seat Ring	Bronze	ASTM B 62
4	Disc	Cast Iron	ASTM A 126 B
5	Disc Washer	Stainless Steel	ANSI 304
6	Disc Nut	Stainless Steel	ANSI 304
7	Stem	Stainless Steel	ANSI 304
8	Gasket	Graphite	Non Asbestos
9	Bolt	Steel	ASTM A 307
10	Packing	Graphite	Non Asbestos
11	Bonnet	Cast Iron	ASTM A 126 B
12	Gland Flange	Ductile Iron	ASTM A536 60-40-18
13	Nut	Steel	ASTM A 307
14	Bolt	Steel	ASTM A 307
15	Stem Nut	Brass	ASTM B584 C84400
16	Handwheel	Cast Iron	ASTM A 126 B
17	Handwheel Washer	Steel	ASTM A 307
18	Handwheel Nut	Steel	ASTM A 307



All data, descriptions and pictures contained in this leaflet may be subject to change without prior notice.

European Casting Industry Srl | Via Lazzaretto, 11 | 20124 Milan MI, Italia | P.Iva: 03228761205 | www.ecivalve.it | info@ecivalve.it