

G 311

CAST IRON CHECK VALVE WAFER TYPE

ANSI 125 WP & PN 16

Conforms to MSS SP-125

www.ecivalve.it

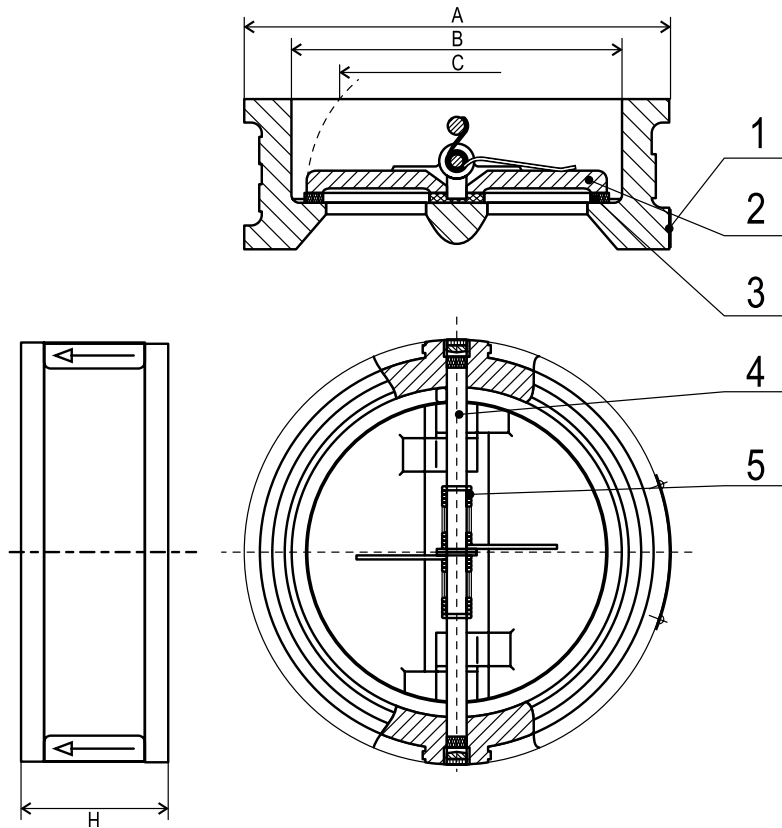

Specifications:

- PRESSURE RATING ANSI 125
- END CONNECTION SUITABLE FOR FLANGE CONNECTION ANSI B16.1 125 OR EN 1092-2 PN16
- USE ONLY FLAT FLANGES AND RING GASKETS
- FACE TO FACE DIMENSIONS CONFORM TO BS EN 558 SERIES 16
- TEMPERATURE OPERATING RANGE -20 TO 120°C
- SUITABLE FOR INSTALLATION IN VERTICAL AND HORIZONTAL PIPELINES
- IN VERTICAL PIPELINES, THE FLOW MUST BE IN AN UPWARD DIRECTION
- NOT SUITABLE FOR STEAM
- SUITABLE MEDIA: WATER, AIR, OIL, ACID AND CORROSIVE MEDIA

Material

No.	DESCRIPTION	MATERIAL	AMERICAN STANDARD
1	Body: Up to 12" 14" to 18"	Cast Iron Ductile Iron	ASTM A 126 B ASTM A536 65-45-12
2	Disc	Stainless Steel	SS304/SS316
3	Liner	EPDM	-
4	Shaft	Stainless Steel	SS410
5	Spring	Stainless Steel	SS316

Dimensions (mm)

DN	SIZE INCH	A	B	C	H	WEIGHT KGS
50	2	105	65	42.5	54	1.5
65	2½	124	80	59.9	54	2.0
80	3	137	94	62.6	57	2.8
100	4	175	117	84.2	64	4.1
125	5	197	145	113	70	6.4
150	6	222	170	141	76	8.5
200	8	279	224	194	95	13.5
250	10	340	265	229	108	22.0
300	12	410	310	279	143	30.0
350	14	451	360	312	184	61.0
400	16	514	410	370	191	78.0
450	18	546	450	414	203	100.0



All data, descriptions and pictures contained in this leaflet may be subject to change without prior notice.

European Casting Industry Srl | Via Lazzaretto, 11 | 20124 Milan MI, Italia | P.Iva: 03228761205 | www.ecivalve.it | info@ecivalve.it