

BR 582

BRONZE GATE VALVE

PN 32

Rising stem

Conforms to BS 5154/MSS SP-80

www.ecivalve.it

ECI EUROPEAN
CASTING
INDUSTRY

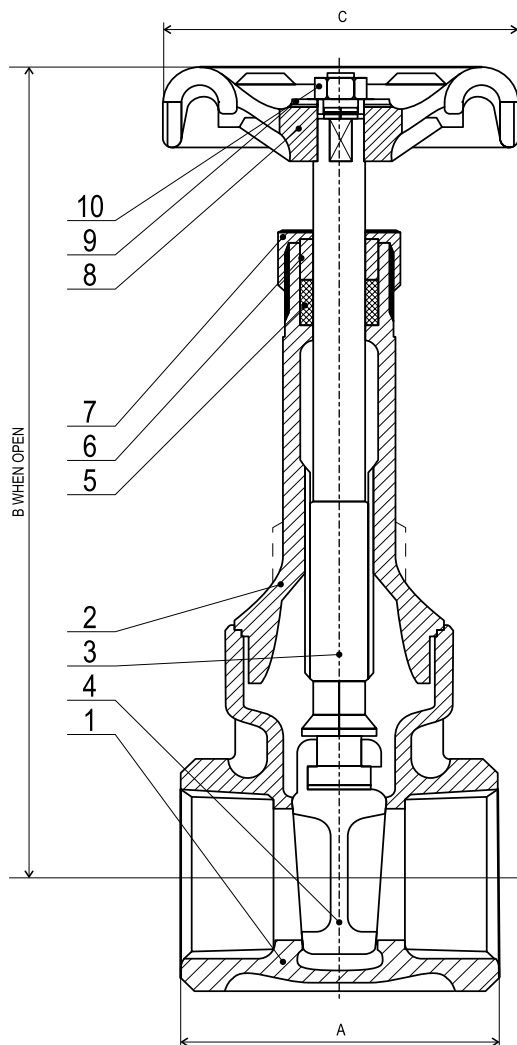

Materials

No.	DESCRIPTION	MATERIAL
1	Body	Bronze CC491K
2	Bonnet	Bronze CC491K
3	Stem	Bronze CC491K
4	Disc	Bronze CC491K
5	Packing	P.T.F.E
6	Clamping Ring	Brass CW614N
7	Packing Nut	Brass CW614N
8	Handwheel	Aluminum
9	Id Plate	Aluminum
10	Handwheel Nut	Brass CW614N

Dimensions (mm)

DN	SIZE INCH	A	B	C	Weight(KGS)
8	¼"	46	126	45	0.320
10	⅜"	46	126	45	0.310
15	½"	51	129	52	0.400
20	¾"	55	159	65	0.643
25	1"	63	189	70	0.998
32	1¼"	72	219	78	1.519
40	1½"	73	246	92	2.064
50	2"	83	301	92	3.191
65	2½"	108	369	134	5.800
80	3"	117	416	134	8.520

Specifications:

- PRESSURE RATING: PN32
- SUITABLE MEDIA: WATER, OIL, AIR & STEAM
- WORKING TEMPERATURE: T ≤ 170°C
- TAPER PIPE THREAD TO NPT AND ISO 7-1 (EX. BS-21)

ECI EUROPEAN
CASTING
INDUSTRY

All data, descriptions and pictures contained in this leaflet may be subject to change without prior notice.

European Casting Industry Srl | Via Lazzaretto, 11 | 20124 Milan MI, Italia | P.Iva: 03228761205 | www.ecivalve.it | info@ecivalve.it